

## Round Service Post 50mm

### AT A GLANCE...

- Size: 50 mm Diameter
- Stock colours: White, Mercury Silver, Anodised and Black
- Length: 3m, 4m or 6m
- Suitable for: Category 6 cabling

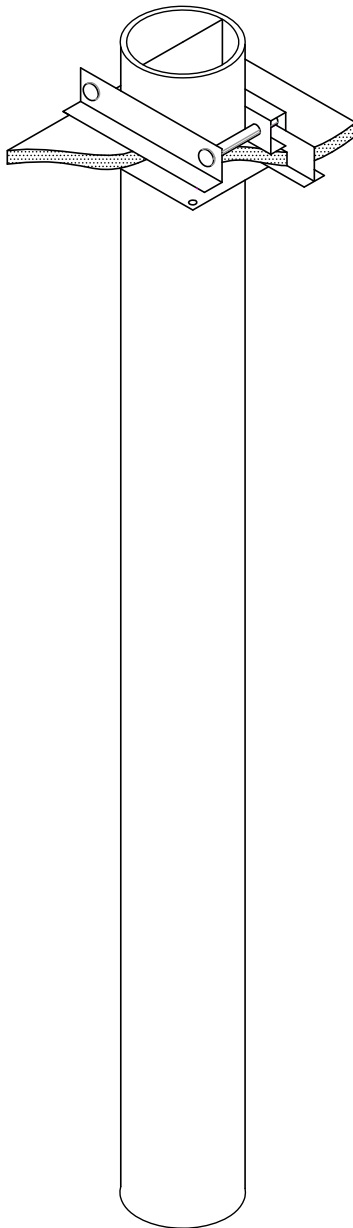

- A neat and attractive extruded aluminium post for the distribution of power and data cables from the ceiling space to the work areas below.
- Suitable for Category 6 data cabling.
- Includes ceiling flange, T-Bar clamp and internal floor bracket or desk mounting plate.
- Includes 2 division segmentation for power and data.
- This product has been examined in accordance with AS 3000 and conforms to A.C.A. requirements.
- Available in White, Mercury Silver, Anodised and Black.
- Available in lengths of 3m, 4m or 6m.

***“Easy as ECD®”***



ESTABLISHED 1979

**Electric Cable Duct Systems P/L**

Phone: 1300 123 ECD (323)

Fax: 1300 372 825

Email: [info@ecd.net.au](mailto:info@ecd.net.au)

website: [www.ecd.net.au](http://www.ecd.net.au)

ABN 80005544105

DETAIL OF SP 50 SERVICE POST FOOTPLATE

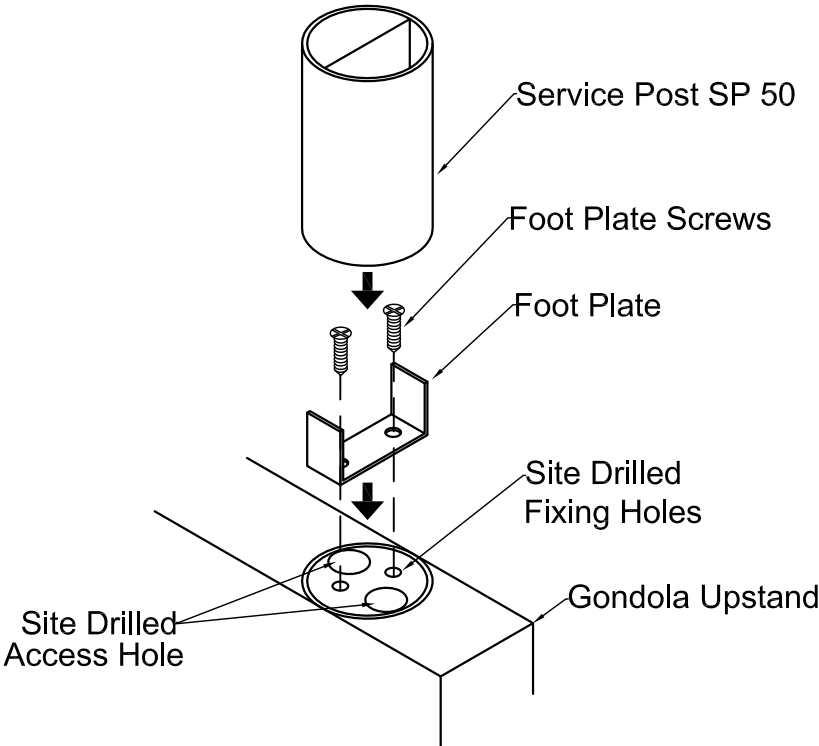

DETAIL OF SP 50 SERVICE POST FIXING TO COUNTER/GONDOLA

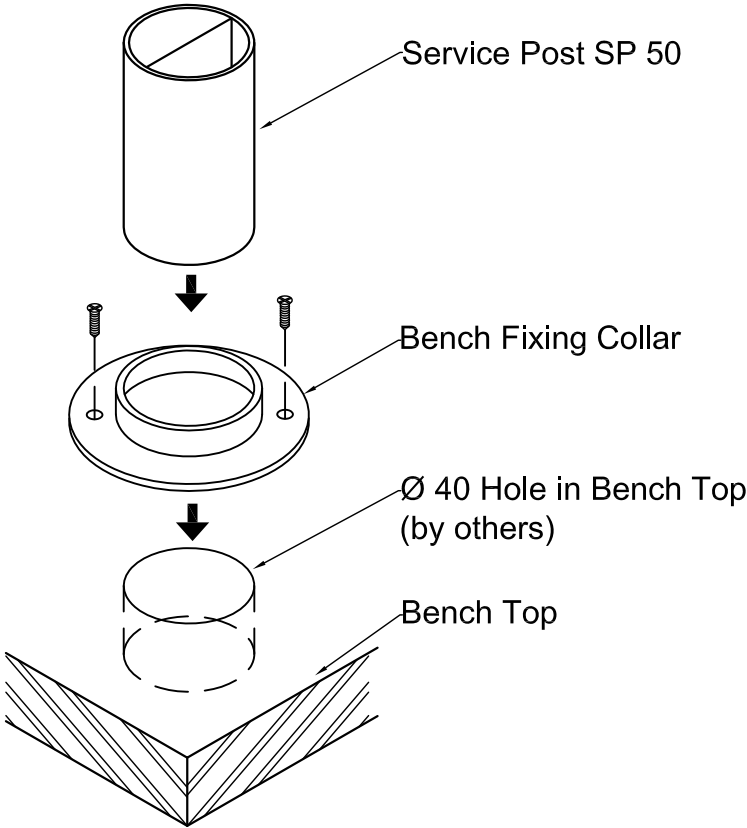

**Electric Cable Duct Systems P/L**

Phone: 1300 123 ECD (323)

Fax: 1300 372 825

Email: [info@ecd.net.au](mailto:info@ecd.net.au)

website: [www.ecd.net.au](http://www.ecd.net.au)