

LOW PROFILE FLOOR DUCT – Surface Mount

AT A GLANCE...

- Mounting: Surface mounted
- Size: 153 x 14 mm
- Body: 2 division extruded aluminium
- Cover: Linished stainless steel also available in black powdercoat

“Easy as ECD®”

- Fully accessible floor duct system suitable for commercial, education and retail applications where chasing of trenches in the concrete floor is not possible or is cost prohibitive.
- Used for reticulation of cables/services to isolated locations within a room/space.
- Can be surface mounted over a variety of floor finishes including tiles, floating timber and carpet.
- Can be suitable for temporary protection of cables over the floor. Note may require earthing in accordance with AS/NZS3000 requirements.
- Extruded aluminium duct body with continuous threadform sections for easy securing of duct covers and other accessories.
- Segregated to suit multiple services including power, data, comms, with offset barrier for greater data/comms capacity.
- Surface mounted duct covers are exposed with countersunk screws for easy cable access.
- Robust stainless steel duct covers to suit foot traffic.
- Duct covers are linished to a number 4 finish to meet P1 requirements for slip resistance in public spaces (dry areas).
- 90 degree bend kits available in left and right hand configurations to assist with easy on site installation.
- Wall and skirting kits available for easy transition of cables into the duct body.
- Compatible with a range of ECD standard surface mount floor boxes and Umbilicals.
- This product has been examined in accordance with AS3000 and A.C.M.A. requirements.

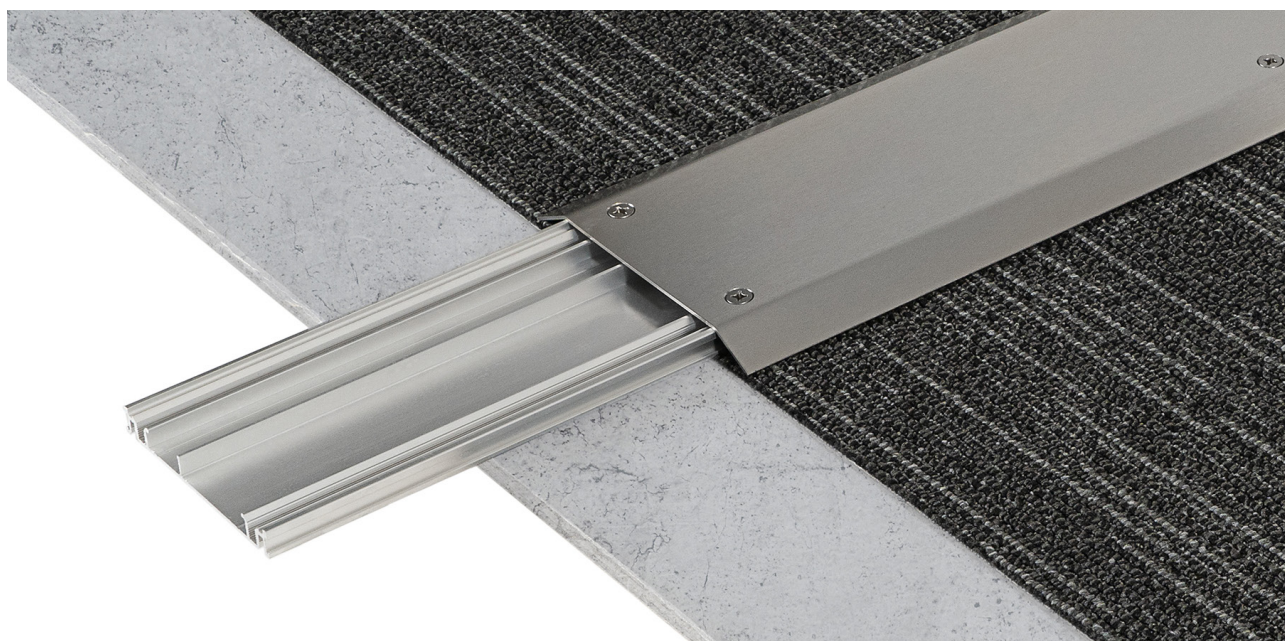

ESTABLISHED 1979

Electric Cable Duct Systems P/L

Phone: 1300 123 ECD (323)

Email: info@ecd.net.au

Fax: 1300 372 825

website: www.ecd.net.au

ABN 80005544105

ASSEMBLY DIAGRAM

LOW PROFILE FLOOR DUCT – SURFACE MOUNT – FFD10012SM

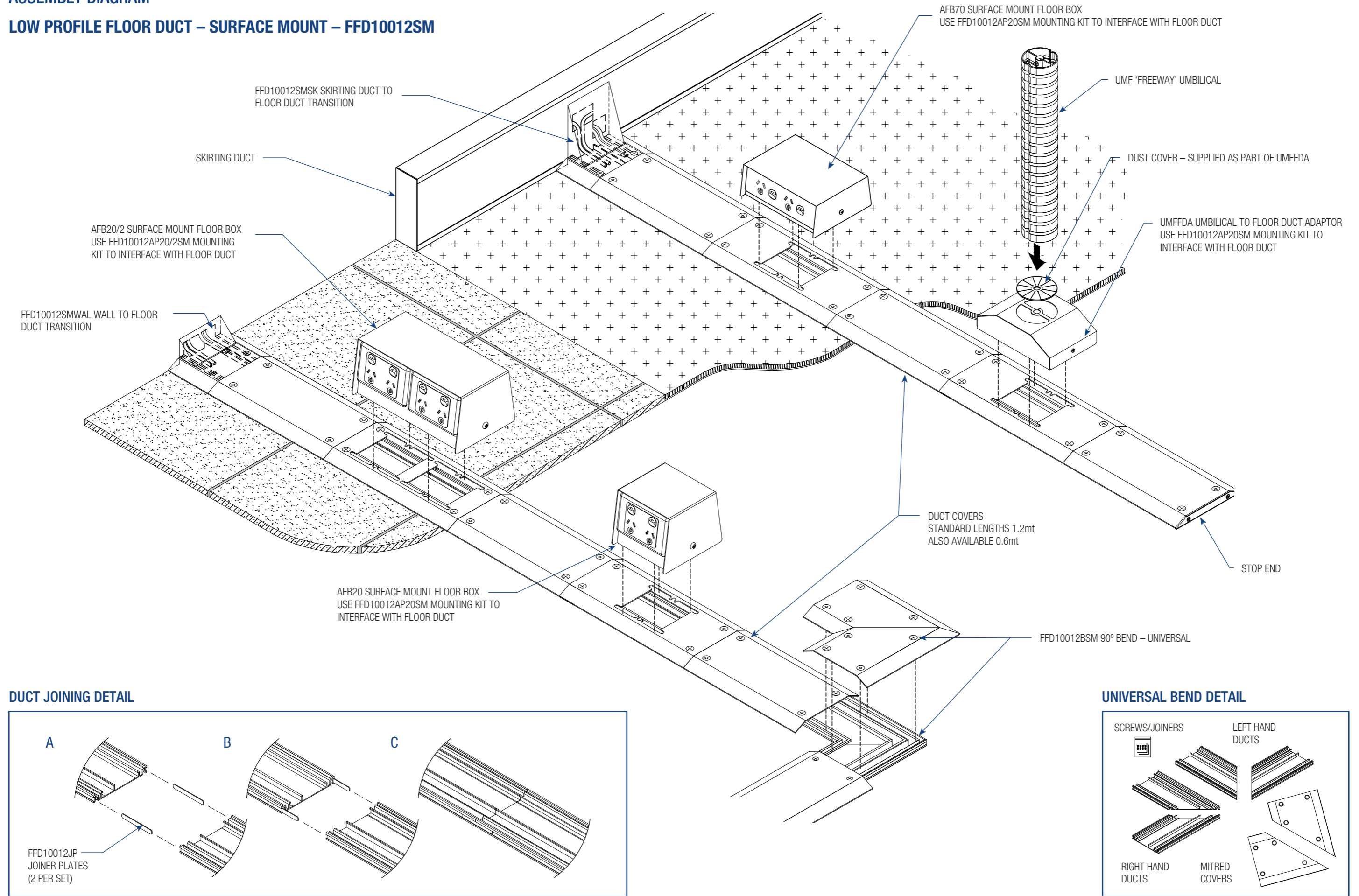

DUCT JOINING DETAIL

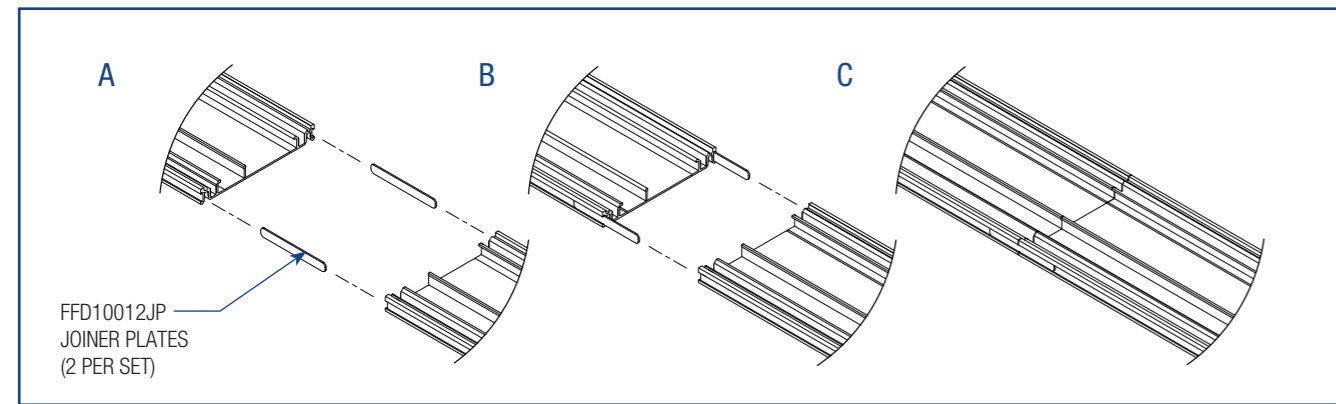

UNIVERSAL BEND DETAIL

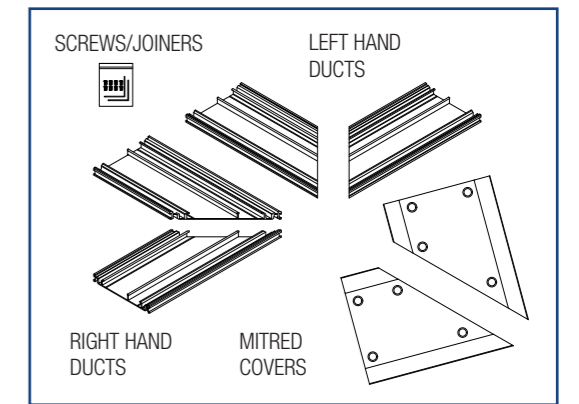

SECTION VIEW

LOW PROFILE FLOOR DUCT – SURFACE MOUNT – FFD10012SM

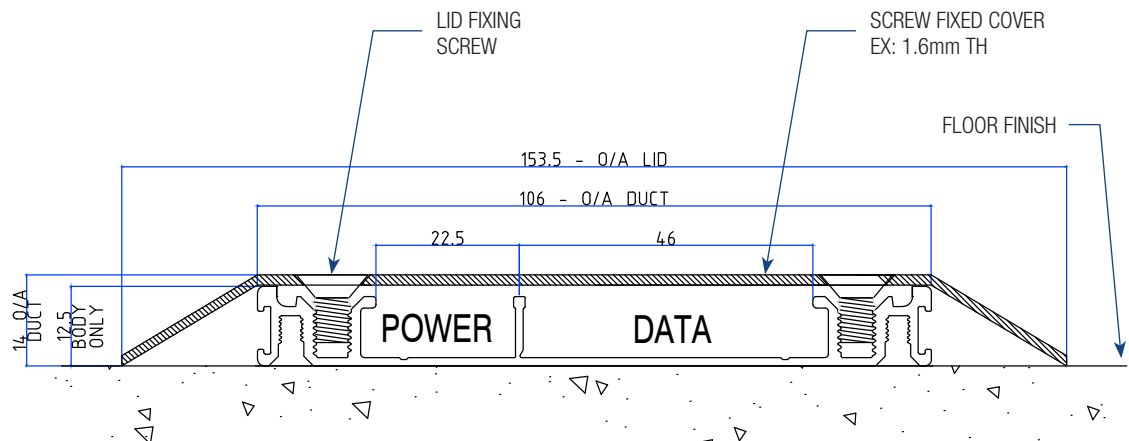

CABLE CAPACITY CHART (ALLOWS FOR 60% AIR SPACE)

POWER CABLES		DATA CABLES		
2.5 mm ²	4.0 mm ²	Cat. 5E	Cat. 6	Cat. 6A
2	1	8	5	4

POINT LOAD TABLE

POINT LOAD SIZE	LOAD TYPE	MAX. LOAD	LOAD CONTACT POINTS
10 x 10 mm	Stiletto heeled shoe	55 kg	2 per shoe (x number of legs)
25 x 25 mm	Chair leg	72 kg	Typically 4 – adjust as required
50 x 50 mm	Castor/wheel	90 kg	Typically 4 – adjust as required

Note: Max load should be multiplied by load contact points per total load.

eg. – chair leg max load 72kg x 4 contact points = 288kg total load

– stiletto heel max load 55kg x 2 contact points = 110kg per foot/leg (x 2 legs = 220kg total load)

PARTS LIST

DESCRIPTION	PART NO.
Floor duct 100 x 12mm Surface Mounted c/w- Stainless Steel covers - 3mt lengths	FFD10012SM**
Stop End - Aluminium	FFD10012SESM**
Bend - 90 degree (universal left or right hand kit)	FFD10012BSM**
Skirting Duct to Floor Duct Transition - suits Surface Mounted (95mm high)	FFD10012SMSK**
Wall to Floor Duct Transition - suits Surface Mounted (40mm high)	FFD10012SMWAL**
Umbilical Adaptor Box (excludes Umbilical) - Stainless Steel	UMFFDA**
Above Floor box Mounting Kit suits AFB20, AFB70, UMFFDA	FFD10012AP20SM**
Above Floor box Mounting Kit suits AFB20/2	FFD10012AP20/2SM**

** Standard finish is Stainless Steel (linished) unless specified. Add 'BK' for Black