

Flush Floor Duct Standard Size

AT A GLANCE...

- Folded metal body with aluminium trim.
- Finishes flush with floor.
- Available with lid trim to suit vinyl floor
- Suitable for all commercial & industrial applications.
- Flush floor cross and tee junction boxes available.
- Leveling plate aids duct height adjustment.
- Suits ECD® floor boxes.

- Fully accessible system suitable for commercial and light industrial applications.
- Galvanised steel duct body with aluminium edge trims.
- Removable screw fixed galvanised steel covers. Covers are pre-punched and countersunk.
- Supplied with leveling / joining brackets prefitted to duct body.
- Leveling / joining brackets provide facility to adjust duct height during installation.
- A full range of flush floor cross-over and tee junction boxes are available.
- This product has been examined in accordance with AS 3000 and A.C.M.A. requirements.

“Easy as ECD®”

SECTION VIEW – FFD SERIES

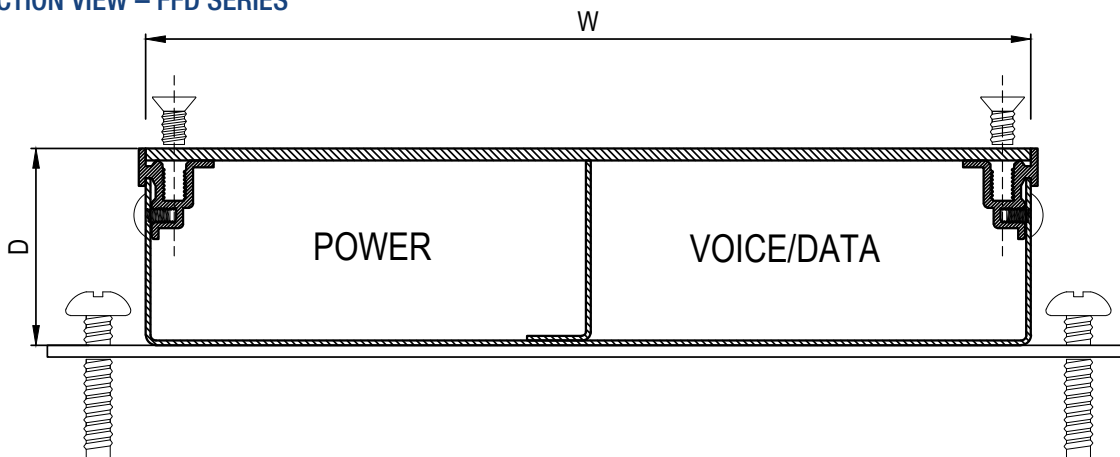

SECTION VIEW – FFDV SERIES WITH UP-STAND FOR VINYL TILES

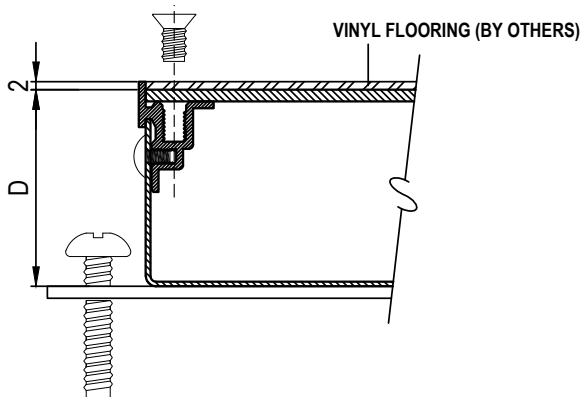

STANDARD SIZE RANGE

CAT. NO	DUCT SIZE (W X D)	RECESS SIZE
FFD11535	115 x 35 mm	190 x 45 mm
FFD22535	225 x 35 mm	300 x 45 mm
FFD22550	225 x 50 mm	300 x 60 mm
FFD35065	350 x 65 mm	420 x 75 mm

‘FFDV’ WITH OPTIONAL VINYL LID TRIM AVAILABLE IN THE STANDARD SIZES ABOVE

*Other sizes available to order



Electric Cable Duct Systems P/L

Phone: 1300 123 ECD (323)

Fax: 1300 372 825

Email: info@ecd.net.au

website: www.ecd.net.au

ABN 80005544105

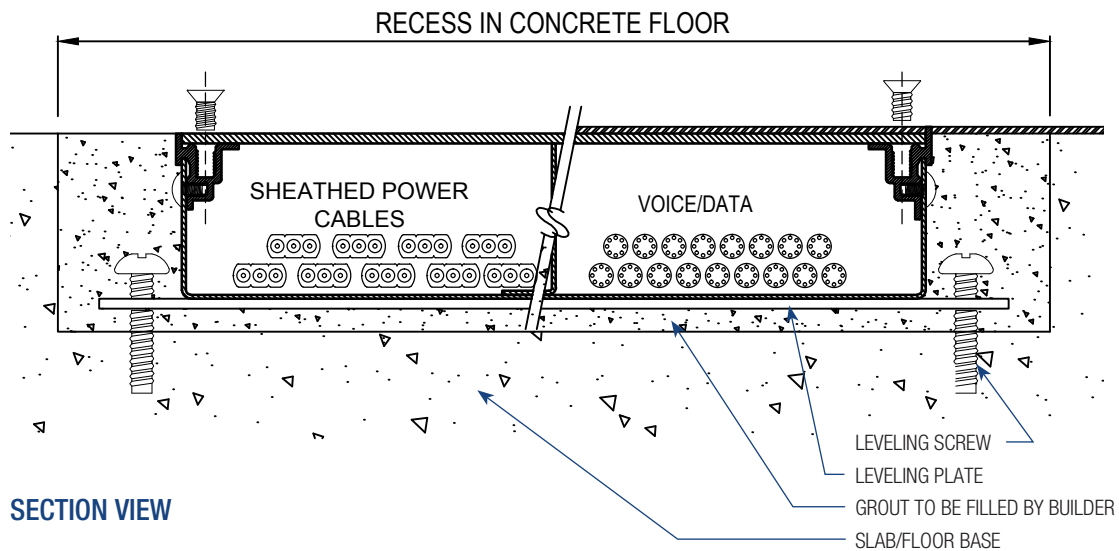

INSTALLATION FFD SERIES

- Installed into a preformed recess provided by the builder (see front page). Once duct is installed and levelled to floor level, the builder is required to grout the location.

SUGGESTED SPECIFICATION

- The contractor shall allow to supply and install Electric Cable Duct Systems P/L Cat No. FFD (see front page), Flush Floor Duct System, generally in accordance with the manufacturers technical publication and as identified on the plans and specifications of the project.
- The body shall be folded steel with aluminium trim with removable pre-punched and countersunk, galvanised steel covers.
- The system shall be a complete and workable system including levelling bracket, stop ends, access inspection ports, and floor outlet boxes.

PARTS LIST

DESCRIPTION	PART NO.	PART NO.	PART NO.	PART NO.
Duct body – 2.4m lengths	FFD11535	FFD22535	FFD22550	FFD35065
Duct cover – 1.2m lengths	FFD11535C	FFD22535C	FFD22550C	FFD35065C
Cross-over junction box	FFD11535X	FFD22535X	FFD22550X	FFD35065X
Tee junction box	FFD11535T	FFD22535T	FFD22550T	FFD35065T
90 degree bend junction	FFD11535B	FFD22535B	FFD22550B	FFD35065B
Access inspection ports	FFD11535AP	FFD22535AP	FFD22550AP	FFD35065AP
Stop End	FFD11535SE	FFD22535SE	FFD22550SE	FFD35065SE
Above Floor Box (Low)	AFB70	AFB70	AFB70	AFB70
Above Floor Box (High)	AFB20	AFB20	AFB20	AFB20