

PROTECTOR™ SERIES HEAVY DUTY Flush Floor Box

Flush, Square Edged, Stainless Steel

AT A GLANCE...

- Features: Load rated with **Cable Shield®** suitable for vehicle traffic – see chart over.
- Capacity: 2 x single auto switch power and 3 x data mounts
- Box Size: 275 x 185 x 80 mm Deep
- Lid Material: Stainless 304 – No. 4 Linished
- Suitable for: Cat6A & 7A Cabling

“Easy as ECD®”

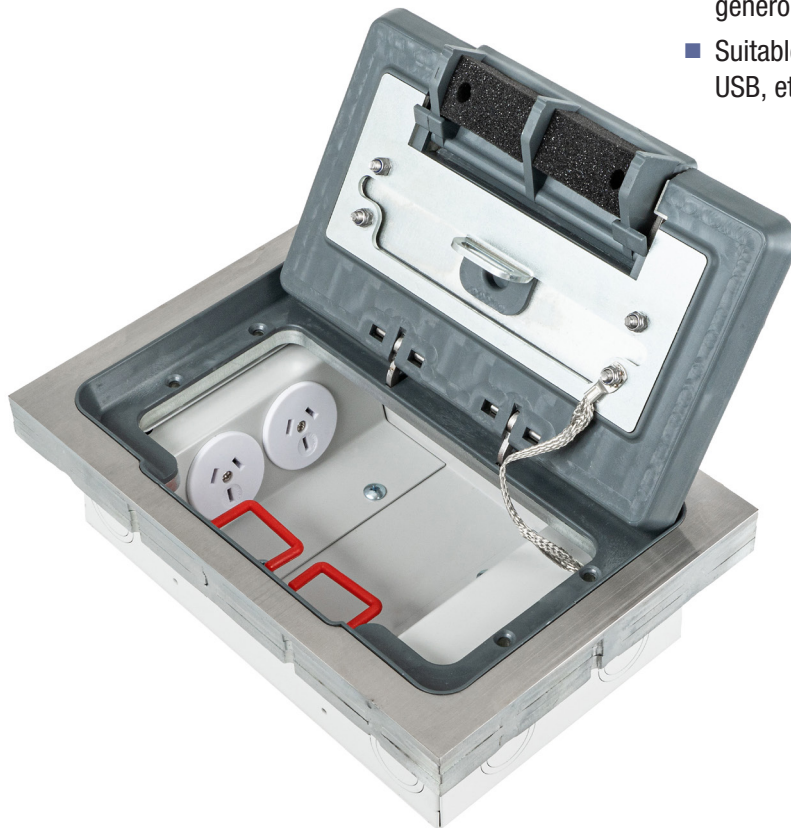

- Heavy duty – load rated floor box suitable for vehicular traffic.
- Ideal for car showrooms and shopping centres.
- Flush Protector™ Series Stainless Steel lid and frame with No. 4 Linished finish.
- Protector™ Series features
 - **Cable Shield®** Frame assembly to prevent cables being cut. (Patent Certified 2017100897 & Patent Pending 2015204344)
 - Cable retainer for easy cable management.
- Frame has square edges (not bevelled) to allow flush fitting to adjacent floor finish (typically timber, tiles or vinyl).
- Robust and large capacity cable exit flap with retracting lifting handle.
- Capacity for 2 x single auto switch power outlets (supplied) and 3 x Data mounts.
- Suitable for category 6A and 7A data cabling with generous bend radius capacity.
- Suitable for Audio / Video outlets including VGA, HDMI, USB, etc.
 - 304 Grade solid Stainless Steel.
 - Modular box body and lid design, interchangeable with plastic and other lids in the ECD® floor box range.
 - Supplied with temporary construction lid.
 - This product has been examined in accordance with AS 3000 and conforms to A.C.M.A. requirements.



ESTABLISHED 1979

Electric Cable Duct Systems P/L

Phone: 1300 123 ECD (323)

Email: info@ecd.net.au

Fax: 1300 372 825

website: www.ecd.net.au

ABN 80005544105

ASSEMBLY DIAGRAM

PROTECTOR™ SERIES HEAVY DUTY FLUSH FLOOR BOX – FLUSH, SQUARE EDGED, STAINLESS STEEL – FB2SHD70

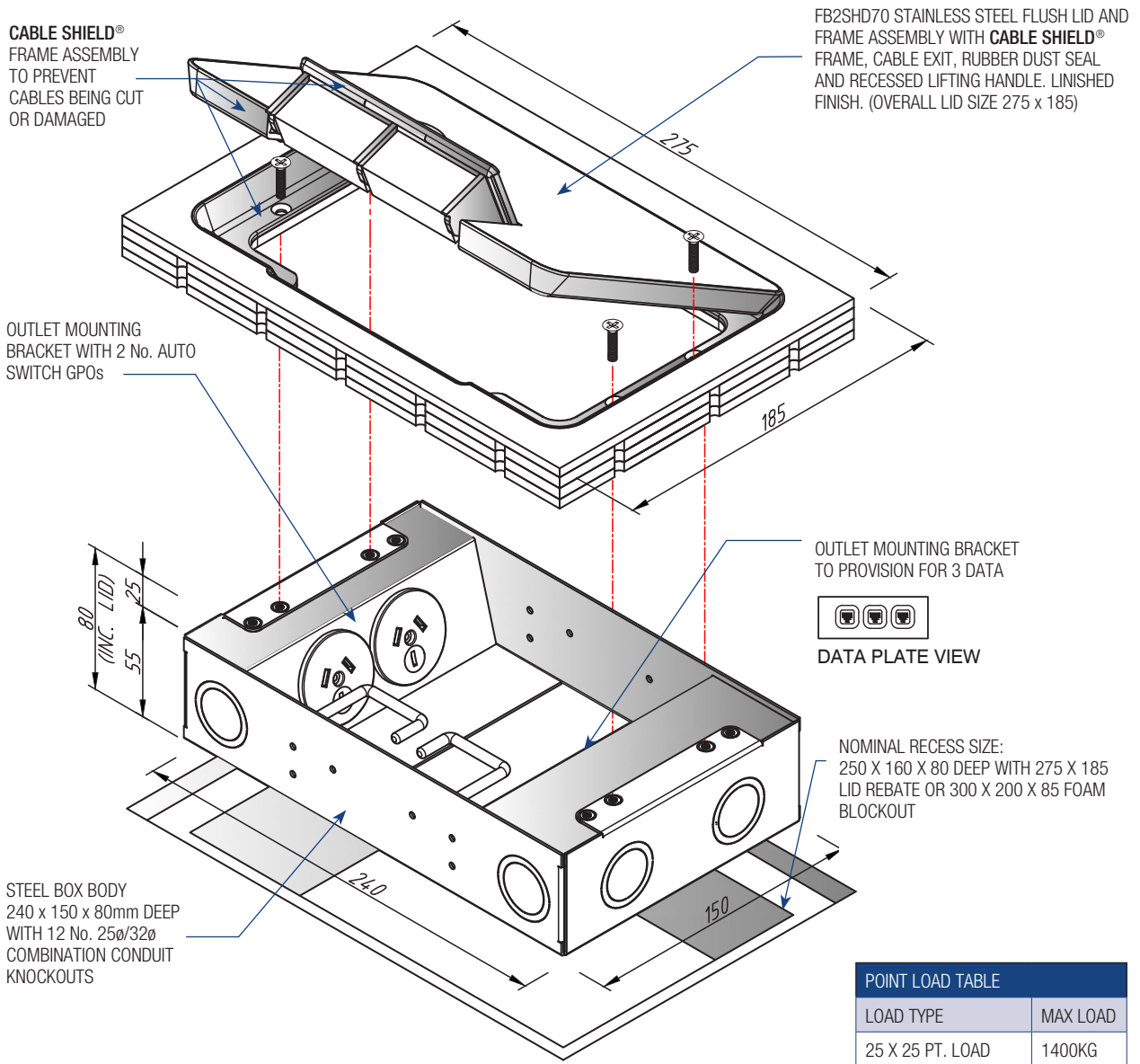

POINT LOAD TABLE	
LOAD TYPE	MAX LOAD
25 X 25 PT. LOAD	1400KG
150 X 60 WHEEL	1550KG
TOTAL VEHICLE (1500KG X 4 WHEELS)	6200KG

NOM. CAR KERB WEIGHT 1800KG
(FALCON/COMMODORE)

