

**PROTECTOR™ SERIES HEAVY DUTY Flush Floor Box**

Flush, Square Edged, Stainless Steel

**AT A GLANCE...**

- Capacity: 2 x single auto switch power and 3 x data
- Box Size: 275 x 185 x 80mm deep
- Features: **Cable Shield®** Frame
- Lid Material: Stainless 304 – No. 4 Linished
- Suitable for: Cat6A & 7A Cabling
- Load Rating: Suitable for vehicle traffic – see chart over

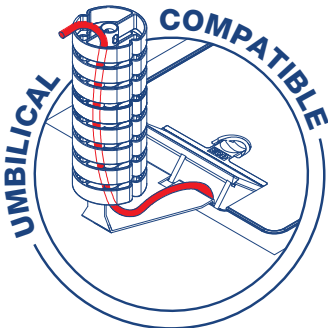

- Heavy duty – load rated floor box suitable for vehicular traffic.
- Ideal for car showrooms and shopping centres.
- Flush Protector™ Series stainless steel lid and frame.
- Protector™ Series features
  - **Cable Shield®** Frame assembly to prevent cables being cut. (Patent Certified 2017100897 & Patent Pending 2015204344)
  - Cable retainer for easy cable management.
- Frame has square edges (not bevelled) to allow flush fitting to adjacent floor finish (typically timber, tiles or vinyl).
- Robust and large capacity cable exit flap with retracting lifting handle.
- Capacity for 2 x single auto switch power outlets (supplied pre-wired) and 3 x data (bezels supplied).
- Suitable for category 6A and 7A data cabling with generous bend radius capacity.
- Suitable for Audio / Video outlets including VGA, HDMI, USB, etc.
- 304 Grade solid stainless steel with No. 4 Linished finish to meet P1 requirements for slip resistance in public spaces (dry areas).
- Modular box body and lid design, interchangeable with plastic and other lids in the ECD® floor box range.
- Supplied with temporary construction lid.
- This product has been examined in accordance with AS 3000 and conforms to A.C.M.A. requirements.

**“Easy as ECD®”**

ESTABLISHED 1979

**Electric Cable Duct Systems P/L**

Phone: 1300 123 ECD (323)

Email: [info@ecd.net.au](mailto:info@ecd.net.au)

Fax: 1300 372 825

website: [www.ecd.net.au](http://www.ecd.net.au)

ABN 80005544105

## ASSEMBLY DIAGRAM

### PROTECTOR™ SERIES HEAVY DUTY FLUSH FLOOR BOX – FLUSH, SQUARE EDGED, STAINLESS STEEL – FB2SHD70

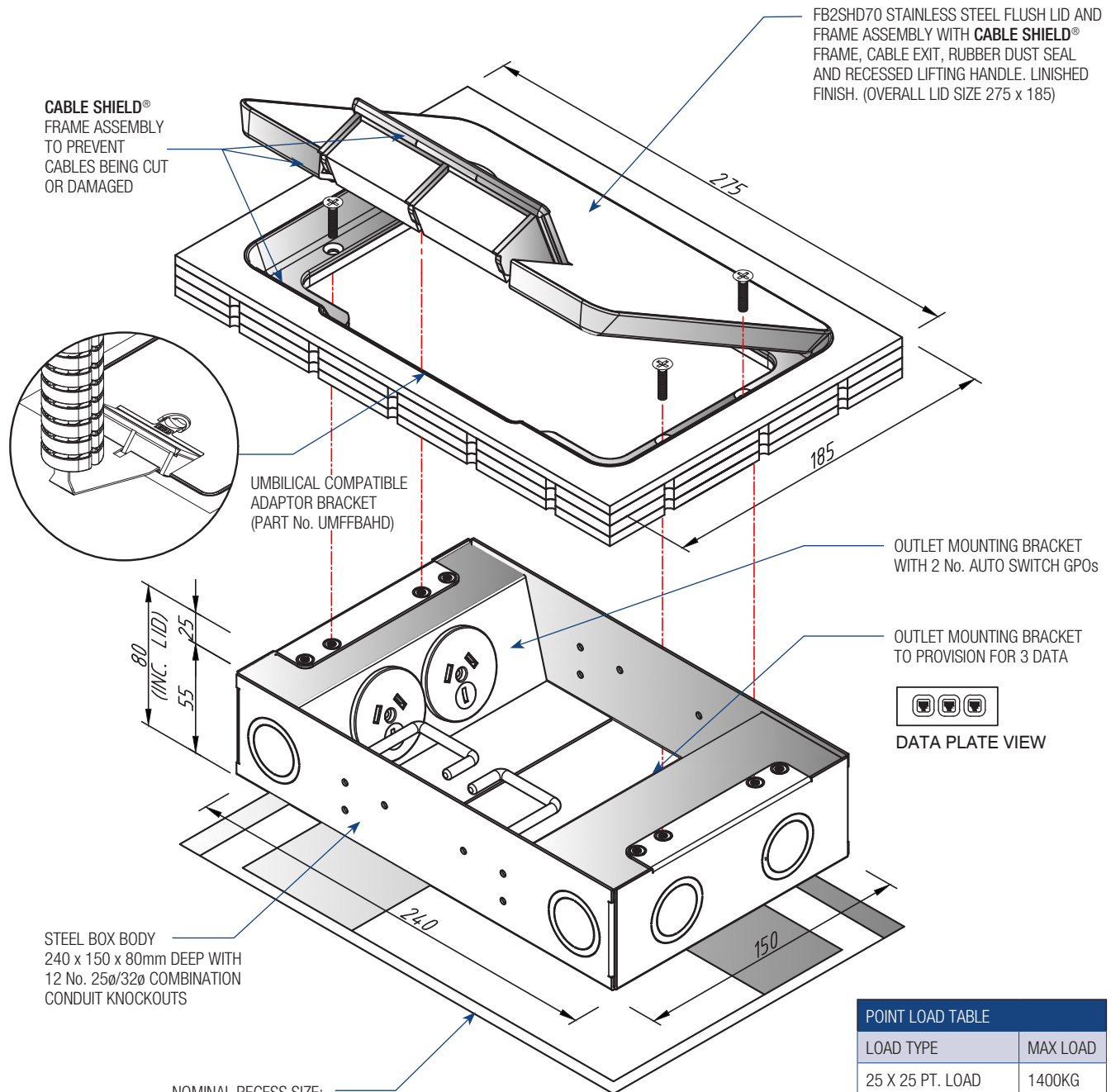

POINT LOAD TABLE	
LOAD TYPE	MAX LOAD
25 X 25 PT. LOAD	1400KG
150 X 60 WHEEL	1550KG
TOTAL VEHICLE (1500KG X 4 WHEELS)	6200KG

NOM. CAR KERB WEIGHT 1800KG  
(FALCON/COMMODORE)

