

PROTECTOR™ SERIES HEAVY DUTY Flush Floor Box

Flush, Square Edged, Stainless Steel

AT A GLANCE...

- Features: Load rated with **Cable Shield®** suitable for vehicle traffic – see chart over.
- Capacity: 2 auto switch GPOs
- Box Size: 150 x 150 x 85 mm Deep
- Lid Material: Stainless 304 – No. 4 Linished
- Suitable for: Compact installations

“Easy as ECD®”

- Heavy duty – load rated floor box suitable for vehicular traffic.
- Ideal for car showrooms and shopping centres.
- Flush Protector™ Series Stainless Steel lid and frame with No. 4 Linished finish.
- Protector™ Series features **Cable Shield®** Frame assembly to prevent cables being cut.
(Patent Certified 2017100897 & Patent Pending 2015204344)
- Frame has square edges (not bevelled) to allow flush fitting to adjacent floor finish (typically timber, tiles or vinyl).
- Robust and large capacity cable exit flap with retracting lifting handle.
- Capacity for 2 x auto switch GPOs (supplied).
- Supplied with temporary construction lid.
- This product has been examined in accordance with AS 3000 and conforms to A.C.M.A. requirements.

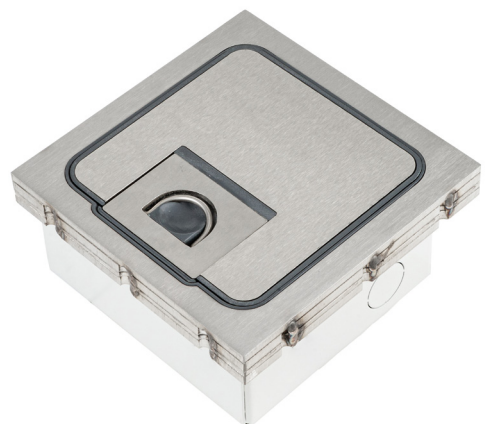

ESTABLISHED 1979

Electric Cable Duct Systems P/L

Phone: 1300 123 ECD (323)

Email: info@ecd.net.au

Fax: 1300 372 825

website: www.ecd.net.au

ABN 80005544105

ASSEMBLY DIAGRAM

PROTECTOR™ SERIES HEAVY DUTY FLUSH FLOOR BOX – FLUSH, SQUARE EDGED, STAINLESS STEEL – FB1SHD70

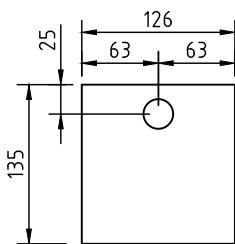
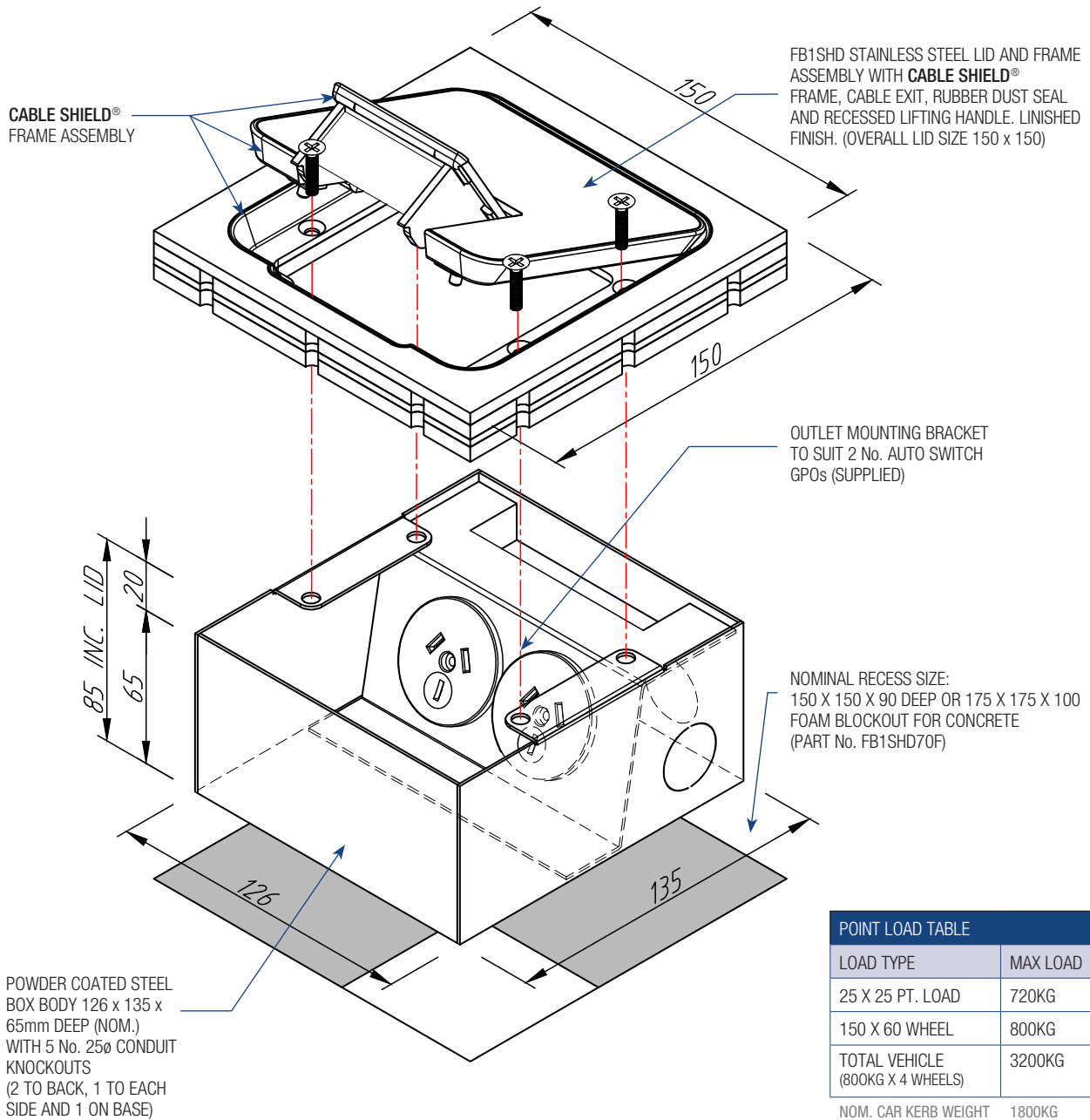

CONDUIT LOCATION
BOX BASE

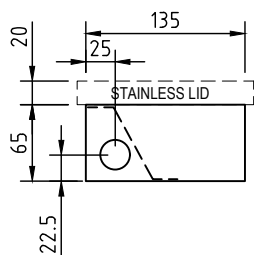

CONDUIT LOCATION
LONG SIDES

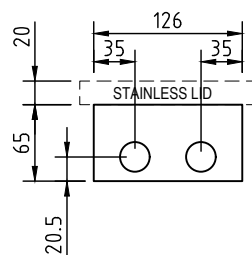

CONDUIT LOCATION
SHORT (HINGE) SIDE

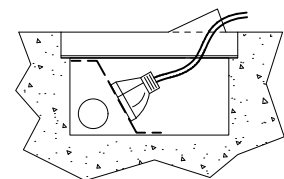

ASSEMBLED SIDE VIEW OF FB1SHD
SINGLE COMPARTMENT FLOOR BOX
SHOWING CABLE EXIT FLAP IN USE