

FB1SDRHD70 FIT OFF GUIDE

STAGE 1 INSTALLATION FLOOR BOX BODY INSTALLATION

FLOOR BOX CAST IN-SITU CONCRETE

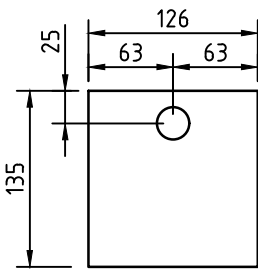
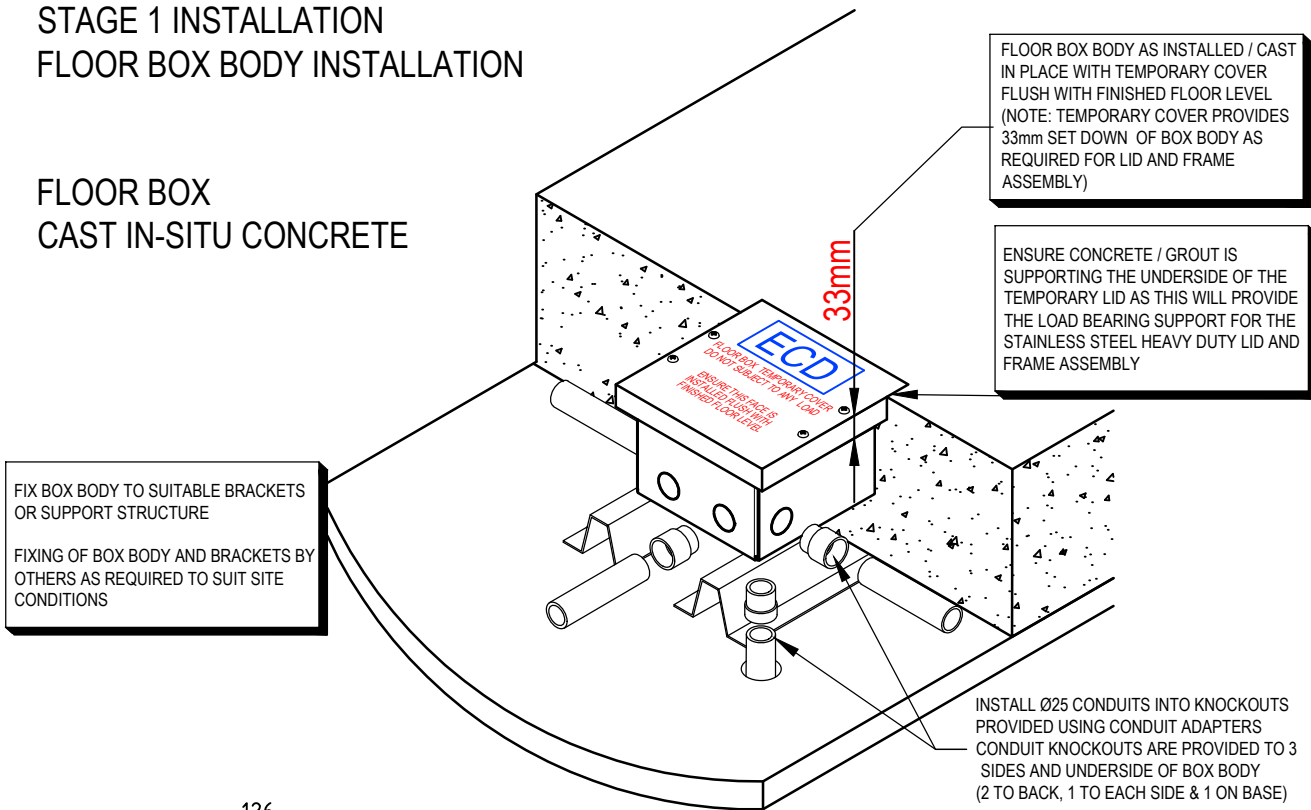

CONDUIT LOCATION
BOX BASE

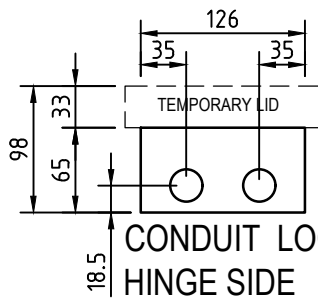

CONDUIT LOCATION
HINGE SIDE

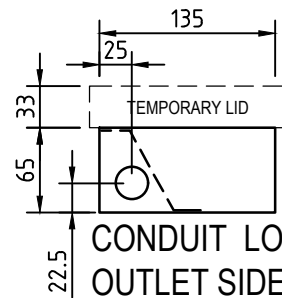

CONDUIT LOCATION
OUTLET SIDES

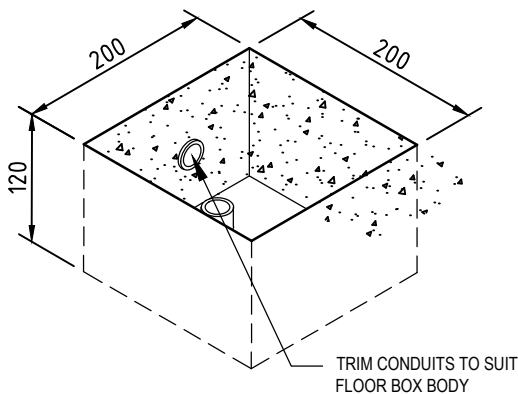

CONCRETE BLOCK OUT

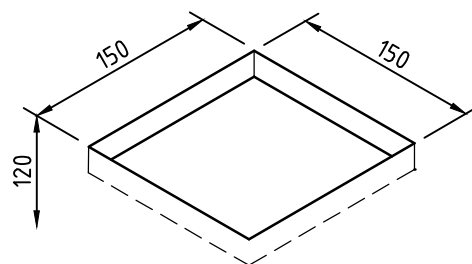

TIMBER FLOOR CUT-OUT



Electric Cable Duct Systems Pty. Ltd.

Ph: 1300 123 ECD (323) Fax: (03) 9899 5042

Email: info@ecd.net.au

www.ecd.net.au

ABN 80005544105

ECD ECD ECD ECD ECD ECD ECD ECD ECD ECD

STAGE 2 INSTALLATION FINAL FIT OFF OF FLOOR BOX

LID AND FRAME ASSEMBLY
FIX TO FLOOR BOX WITH
4 No. M4 X 20 CSK SCREWS SUPPLIED

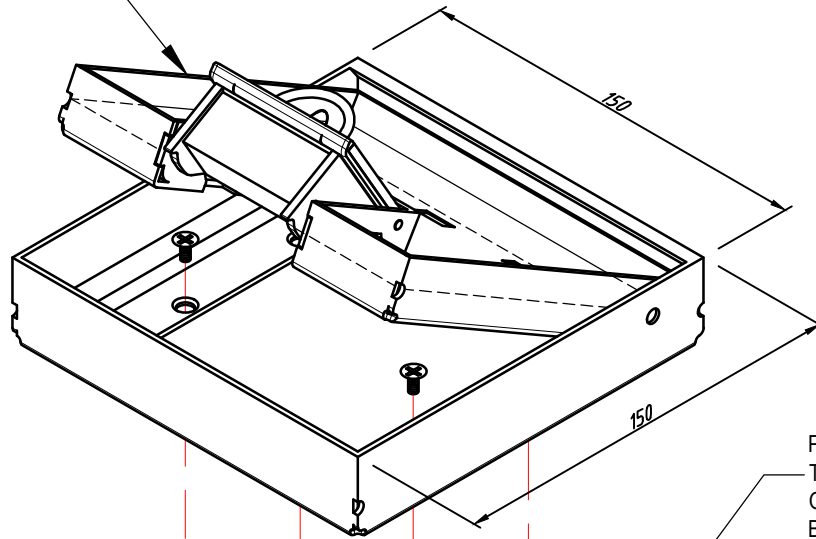

POWER OUTLET MOUNTING
TO SUIT 2 No. AUTO SWITCH
GPO's FIX PLATE TO BOX
BODY WITH 1 No. MUSHROOM
HEAD SCREWS PROVIDED

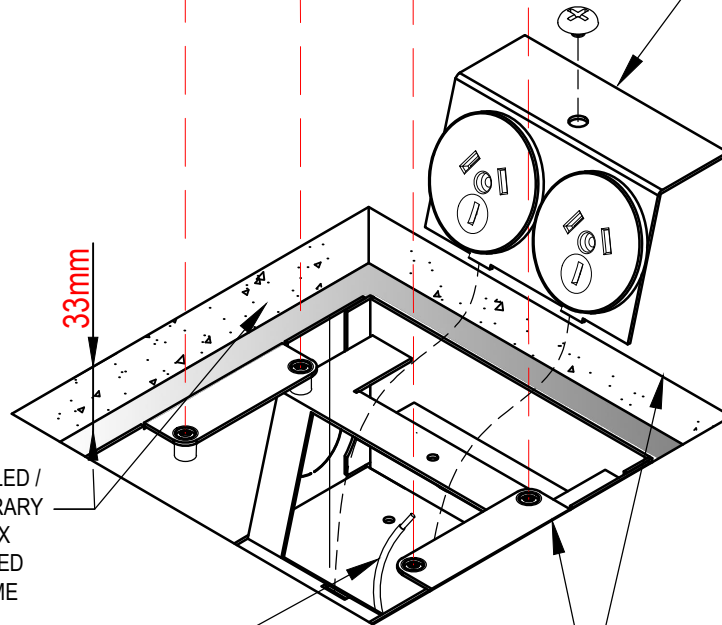

FLOOR BOX BODY AS INSTALLED /
CAST IN PLACE WITH TEMPORARY
COVER REMOVED. (NOTE: BOX
BODY IS 33mm BELOW FINISHED
FLOOR TO SUIT LID AND FRAME
ASSEMBLY)

FLOOR BOX BODY EARTH TAIL
ENSURE CONNECTION TO EARTH
CIRCUIT TO OBTAIN CORRECT EARTHING
AS REQUIRED FOR FLOOR BOX BODY

CUT CARPET/VINYL/FLOOR
COVERING TO THIS EDGE



Electric Cable Duct Systems Pty. Ltd.

Ph: 1300 123 ECD (323) Fax: (03) 9899 5042

Email: info@ecd.net.au

www.ecd.net.au

ABN 80005544105