

## Stainless Steel Floor Box 20mm Deep Recess

### AT A GLANCE...

- Capacity: 1 standard size GPO  
1 No. 3 gang data plate
- Box Size: 150 x 150 x 127mm deep
- Lid Material: Stainless steel
- Lid Rebate: 20mm deep
- Suitable for: Compact installations
- Load Rating: 120kg (per foot = foot traffic)

**“Easy as ECD®”**

- A versatile, practical and decorative solution for your open plan cabling needs.
- Recessed stainless steel lid and frame with 20mm rebate for floor finish (typically polished timber boards or ceramic tiles).
- Frame has square edges (not bevelled) to allow flush fitting to adjacent floor finish.
- 304 Grade solid stainless steel lid construction with No. 4 Linished finish.
- Robust cable exit flap with Cable Shield® and stainless steel lifting handle.
- Capacity 1 x double GPO and 3 x data (grid plate supplied).
- Suitable for Audio / Video outlets including VGA, HDMI, USB, etc.
- Supplied with temporary construction lid.
- This product has been examined in accordance with AS 3000 and conforms to A.C.M.A. requirements.



ESTABLISHED 1979

**Electric Cable Duct Systems P/L**

Phone: 1300 123 ECD (323)

Email: [info@ecd.net.au](mailto:info@ecd.net.au)

Fax: 1300 372 825

website: [www.ecd.net.au](http://www.ecd.net.au)

ABN 80005544105

## ASSEMBLY DIAGRAM

### STAINLESS STEEL FLOOR BOX – 20MM DEEP RECESS – FB1SDR

FB1SDR STAINLESS STEEL LID AND FRAME ASSEMBLY WITH 20mm DEEP RECESS, CABLE EXIT FLAP, RUBBER DUST SEAL AND RECESSED LIFTING HANDLE (150 X 150 X 32mm O/A)

CABLE SHIELD® TO CABLE EXIT FLAP ASSEMBLY

OUTLET MOUNTING BRACKET TO SUIT 1 No. 3 GANG ARCHITRAVE PLATE FOR DATA / A.V.

\*ASSESS SUITABILITY PRIOR TO INSTALLATION TO ENSURE AVAILABLE DATA SPACE IS SUFFICIENT TO MEET SPECIFIC REQUIREMENTS

OUTLET MOUNTING BRACKET TO SUIT 1 No. STANDARD POWER OUTLET PLATE

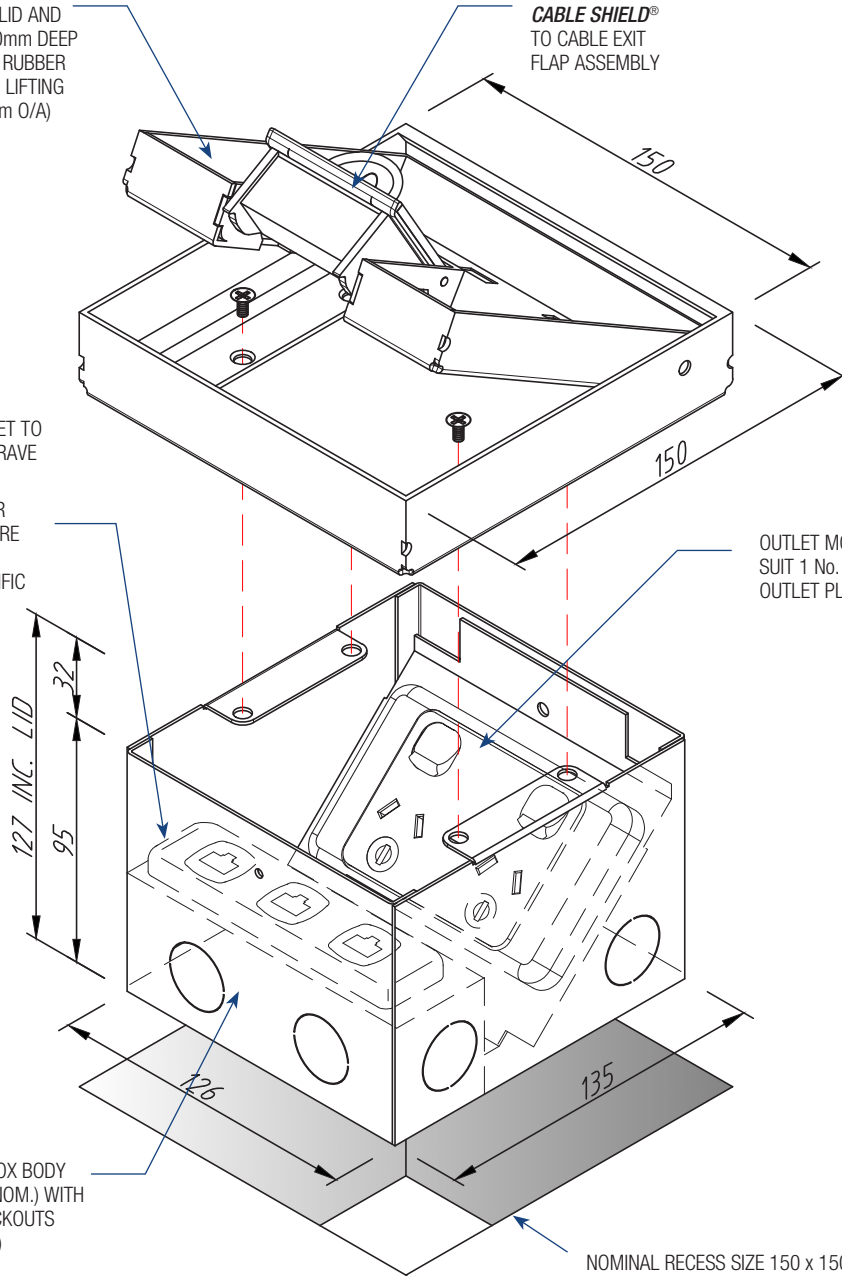

POWDER COATED STEEL BOX BODY 126 x 135 x 95mm DEEP (NOM.) WITH 10 No. 25 $\phi$  CONDUIT KNOCKOUTS (2 EACH SIDE & 2 ON BASE)

NOMINAL RECESS SIZE 150 x 150 x 135 DEEP FOR TIMBER FLOOR OR 175 x 175 x 140 FOAM BLOCKOUT FOR CONCRETE (PART No. FB1F)

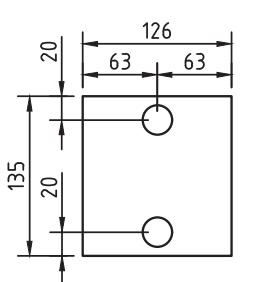

CONDUIT LOCATION BOX BASE

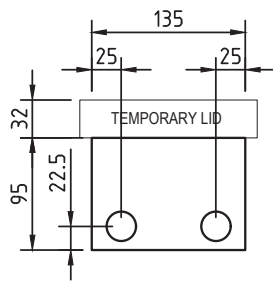

CONDUIT LOCATION LONG SIDES

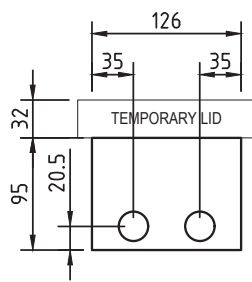

CONDUIT LOCATION SHORT (HINGE & EXIT) SIDES

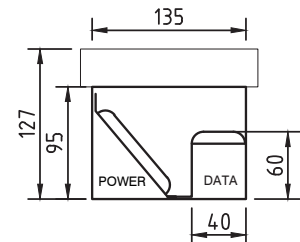

SECTION THRU' BOX