

Brass Floor Box Heavy Duty 12mm Deep Recess**AT A GLANCE...**

- Capacity: 2 x single auto switch power outlets
- Box Size: 150 x 150 x 97mm deep
- Lid Material: Brass
- Lid Rebate: 12mm deep
- Suitable for: Heavy duty installations
- Load Rating: Suits vehicle traffic – see chart over

- A versatile, practical and decorative solution for your open plan cabling needs.
- Heavy duty – load rated floor box suitable for vehicular traffic.
- Ideal for car showrooms and shopping centres.
- 12mm rebate for floor finish (typically timber boards or ceramic tiles).
- Frame has square edges (not bevelled) to allow flush fitting to adjacent floor finish.
- Brass lid construction with No. 4 Linished finish.
- Robust, large cable exit flap with Cable Shield® and brass lifting handle.
- Capacity for 2 x single auto switch power outlets (supplied).
- Supplied with temporary construction lid.
- This product has been examined in accordance with AS 3000 and conforms to A.C.M.A. requirements.

“Easy as ECD®”

ESTABLISHED 1979

Electric Cable Duct Systems P/L

Phone: 1300 123 ECD (323)

Fax: 1300 372 825

Email: info@ecd.net.auwebsite: www.ecd.net.au

ABN 80005544105

ASSEMBLY DIAGRAM

BRASS FLOOR BOX – HEAVY DUTY 12MM DEEP RECESS – FB1BDRHD70

FB1BDRHD BRASS LID AND FRAME ASSEMBLY WITH REINFORCING PLATE, 12mm DEEP RECESS, CABLE EXIT FLAP, RUBBER DUST SEAL AND RECESSED LIFTING HANDLE (150 X 150 X 32mm O/A)

CABLE SHIELD® TO CABLE EXIT FLAP ASSEMBLY

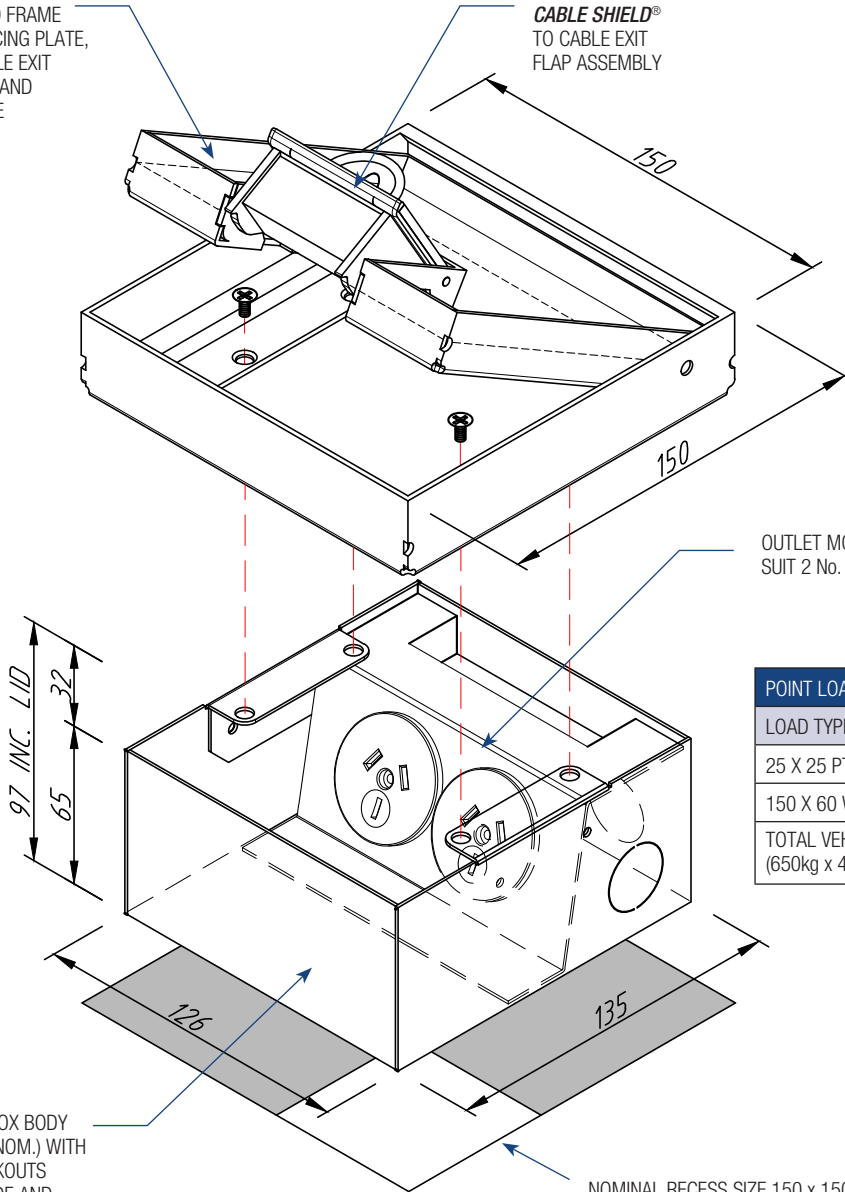

OUTLET MOUNTING BRACKET TO SUIT 2 No. AUTO SWITCH GPOs

POINT LOAD TABLE	
LOAD TYPE	MAX LOAD
25 X 25 PT. LOAD	500kg
150 X 60 WHEEL	650kg
TOTAL VEHICLE (650kg x 4 wheels)	2,600kg

POWDER COATED STEEL BOX BODY 126 x 135 x 65mm DEEP (NOM.) WITH 5 No. 25ø CONDUIT KNOCKOUTS (2 TO BACK, 1 TO EACH SIDE AND 1 ON BASE)

NOMINAL RECESS SIZE 150 x 150 x 105 DEEP FOR TIMBER FLOOR OR 175 x 175 x 110 FOAM BLOCKOUT FOR CONCRETE (PART No. FB170F)

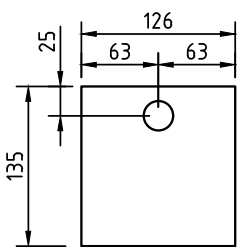

CONDUIT LOCATION BOX BASE

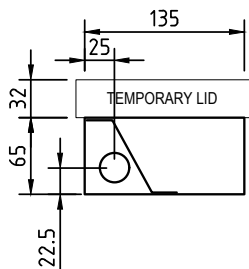

CONDUIT LOCATION LONG SIDES

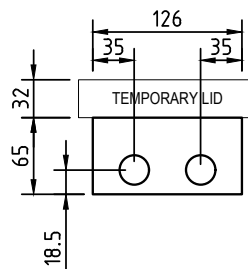

CONDUIT LOCATION SHORT (HINGE) SIDE

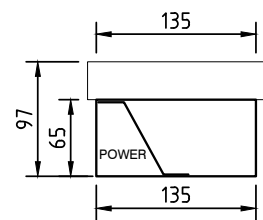

SECTION THRU' BOX