

UMBILICAL TO FLOOR BOX ADAPTOR CAT. NO. **UMFFBAHD***

(Excludes Umbilical)

*NOMINATE COLOUR – BLACK-BK, WHITE-WE, SILVER-SR



UMBILICAL TO FLOOR BOX CONNECTION – HEAVY DUTY STAINLESS STEEL LIDS

Example indicative of umbilical connection to floor boxes with heavy duty stainless steel lids

Refer to floor box catalogue pages for specific models including –

- FB2SHD ■ FB6SHD
- FB2SHD70 ■ FB6SHD70
- FB4SHD
- FB4SHD70

UMBILICALS TO BE ORDERED SEPARATELY	
LENGTH	PART NO.
780mm	UMF780* c/w UNDER DESK MOUNT
3000mm	UMF3000FM* c/w CEILING MOUNT
4000mm	UMF4000FM* c/w CEILING MOUNT
6000mm	UMF6000FM* c/w CEILING MOUNT

*NOMINATE COLOUR – BLACK-BK, WHITE-WE, SILVER-SR, TRANSLUCENT-TR

Refer to UMFFBAHD fit-off guide for connection details.

“Easy as ECD®”

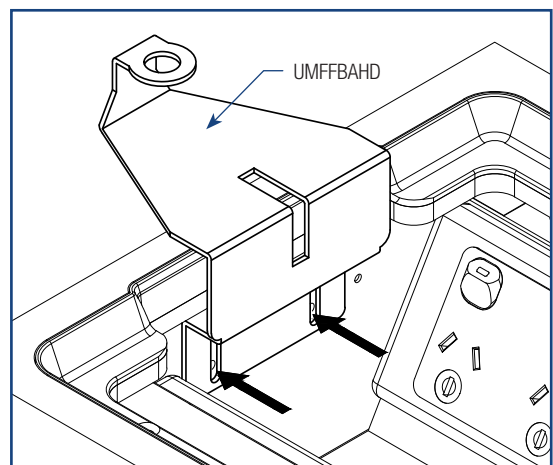

Electric Cable Duct Systems P/L

Phone: 1300 123 ECD (323)

Email: info@ecd.net.au

Fax: 1300 372 825

website: www.ecd.net.au

ABN 80005544105