

Bollard Galvanised Steel**AT A GLANCE...**

- Size: 100 x 100 x 600 mm High (160 x 160 mm Base)
- Capacity: 2 No. IP66 industrial socket modules
- Features: Surface mounting of outlets
- Suitable for: External use



- A neat and attractive, square (100 x 100 mm) hot dipped galvanised steel bollard suitable for external use.
- Fabricated from mild steel, welded, dressed and hot dipped galvanised.
- Outlets are surface mounted – less enclosure/s.
- Capacity for 2 No. IP66 industrial socket modules – 1 x switch/power combination; 2 x auto switch power or 1 x auto switch power/data combination (with optional barrier fitted).
- This product has been examined in accordance with AS 3000 and conforms to A.C.M.A. requirements.
- Custom configurations are available to order. Please refer to B0100 made to order template on website.

“Easy as ECD®”



ESTABLISHED 1979

Electric Cable Duct Systems P/L

Phone: 1300 123 ECD (323)

Fax: 1300 372 825

Email: info@ecd.net.auwebsite: www.ecd.net.au

ABN 80005544105

ASSEMBLY DIAGRAM

100 X 100 MM GALVANISED STEEL BOLLARD – B0100GAL

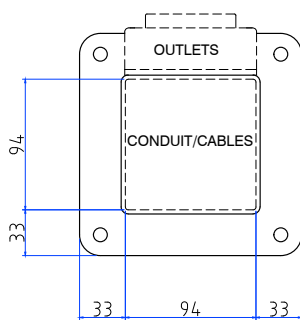
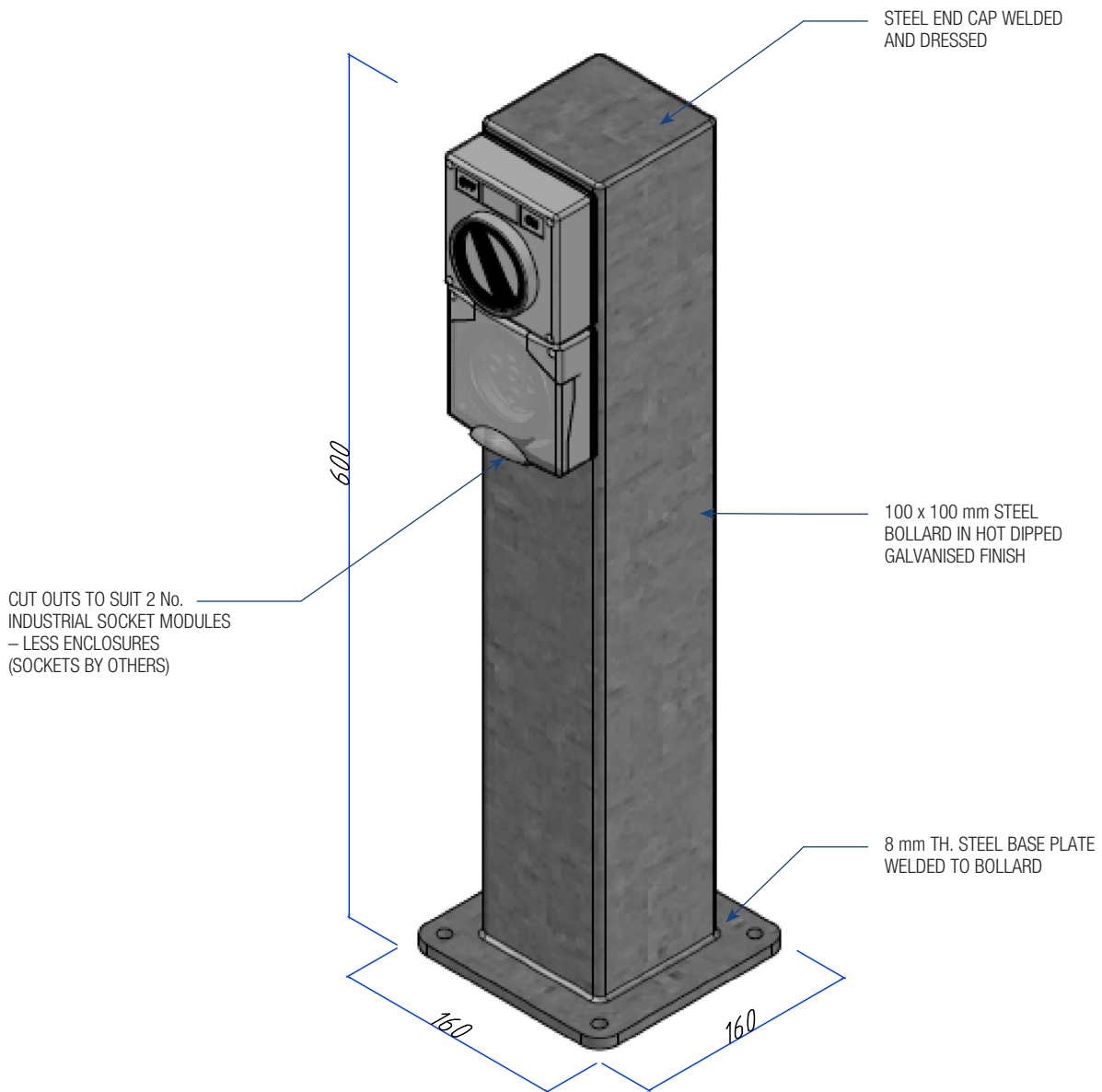

CONDUIT PROVISION
PLAN VIEW

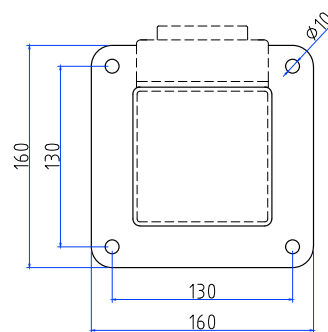

BASE MOUNTING PROVISION
PLAN VIEW