

Above Floor Box

AT A GLANCE...

- Size: 160 x 127 x 50 mm
- Outlets: 1 x Universal 10/15 Amp single GPO & 2 x Data mounts
- Stock Colours: Black

“Easy as ECD®”

- Low profile, surface mounted floor box designed specifically for the fitness industry.
- Can be used in conjunction with AFD35 Above Floor Duct or as a stand alone floor box.
- Standard arrangement 1 x Universal 10/15 Amp single auto switch GPO and 2 x data mounts.
- Custom configurations available through optional mounting plates.
- Flexible power, data and TV plates within a small box.
- Suitable for Category 6 data cabling and TV outlets.
- Robust steel construction.
- Powder coat finish in standard colour black. Other colours are available to order.
- This product has been examined in accordance with AS 3000 and conforms to A.C.A. requirements.



ESTABLISHED 1979

Electric Cable Duct Systems P/L

Phone: 1300 123 ECD (323)

Email: info@ecd.net.au

Fax: 1300 372 825

website: www.ecd.net.au

ABN 80005544105

ASSEMBLY DIAGRAM

ABOVE FLOOR BOX – AFB35 SERIES

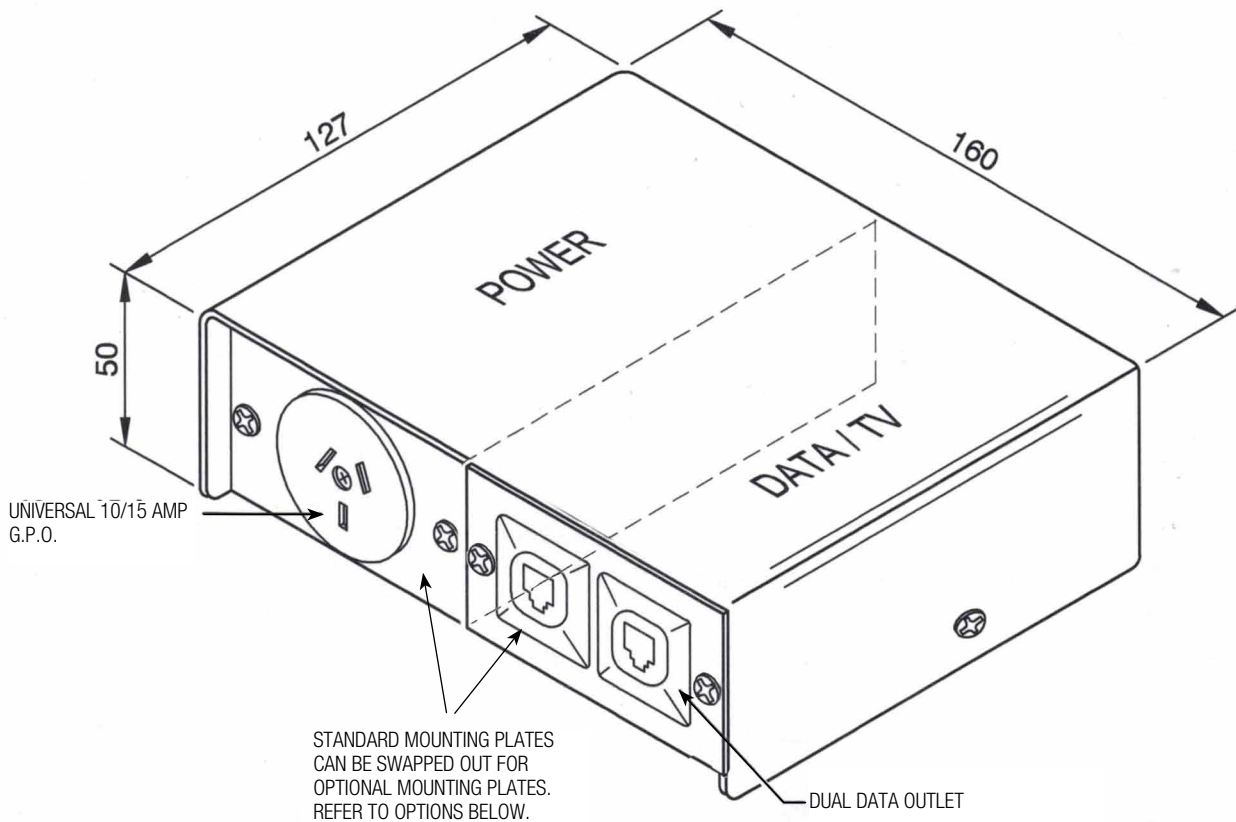

PART NO.	CONFIGURATION
AFB35BK	1 x Universal 10/15 amp GPO and 2 x data mounts

OPTIONAL MOUNTING PLATES

PART NO.	CONFIGURATION
AFB351PBK	1 gang GPO plate c/w Universal 10/15 amp GPO
AFB352DBK	2 gang Data Plate